

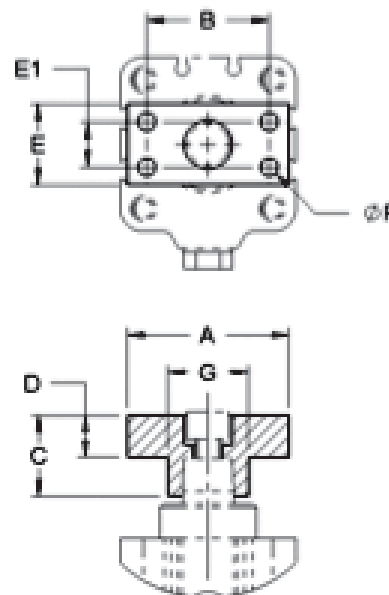

Blank Clamping Arm

Features:

- For attaching custom made clamp arms
- 360° rotatable arm
- Aluminum construction

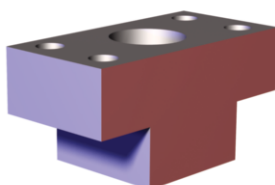
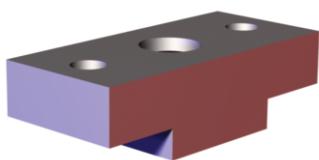

| Part Number | Used with Model/series | A | B | C | D | E | E1 | F | Weight [lbs] kg |
|------------------|------------------------|--------|--------|--------|--------|--------|--------|----------|-----------------|
| 8MA-084-1 | 89R20-010-2 | [1.57] | [1.10] | [0.59] | [0.32] | [0.59] | -- | | [0.03] |
| | 89B20-010-1 | 40 | 28 | 15 | 8 | 15 | | | 0,014 |
| | 89E20-010-1 | | | | | | | [0.22] | |
| 8MA-086-1 | 89R32-010-2 | | [1.38] | [0.79] | [0.43] | [0.79] | -- | 5,5 (2x) | [0.08] |
| | 89B30-010-1 | | 35 | 20 | 11 | 20 | | | 0,035 |
| | 89E30-010-1 | | | | | | | | |
| 8MA-087-1 | 89R40-010-2 | [1.97] | | | | | | | |
| | 89R40-025-2 | 50 | | | | | | | |
| | 89B40-010-1 | | [1.50] | [0.98] | [0.51] | [0.98] | [0.55] | [0.22] | [0.11] |
| | 89E40-010-1 | | 38 | 25 | 13 | 25 | 14 | 5,5 (4x) | 0,050 |
| 8MA-088-1 | 89R50-025-2 | [2.36] | [1.77] | [1.18] | [0.59] | [1.18] | [0.59] | [0.28] | [0.19] |
| | 89B50-025-1 | 60 | 45 | 30 | 15 | 30 | 15 | 7 (4x) | 0,085 |
| | 89E50-025-1 | | | | | | | | |
| 8MA-089-1 | 89R63-025-2 | [2.56] | [1.89] | [1.38] | [0.67] | [1.38] | [0.71] | [0.35] | 0.28 |
| | 89B63-008-1 | 65 | 48 | 35 | 17 | 35 | 18 | 9 (4x) | 0,125 |
| | 89E63-008-1 | | | | | | | | |
| 801532 | 8015/8016 | [1.37] | [1.00] | [0.39] | [0.25] | [0.62] | -- | #10-32 | [0.03] |
| | 8115/8116 | 34,8 | 25,4 | | | | | (2x) | 0,014 |
| 821556 | 8215/8216 | [1.50] | [1.06] | [0.75] | [0.37] | [0.75] | -- | 1/4-20 | [0.05] |
| | 8315/8316 | 38,1 | 26,9 | | | | | (2x) | 0,020 |

Mounting Feet

Features:

- Can be mounted on bottom side or front side
- Can be mounted on 4 sides of the cylinder
- For use with **89R** Series Pneumatic Swing Clamps

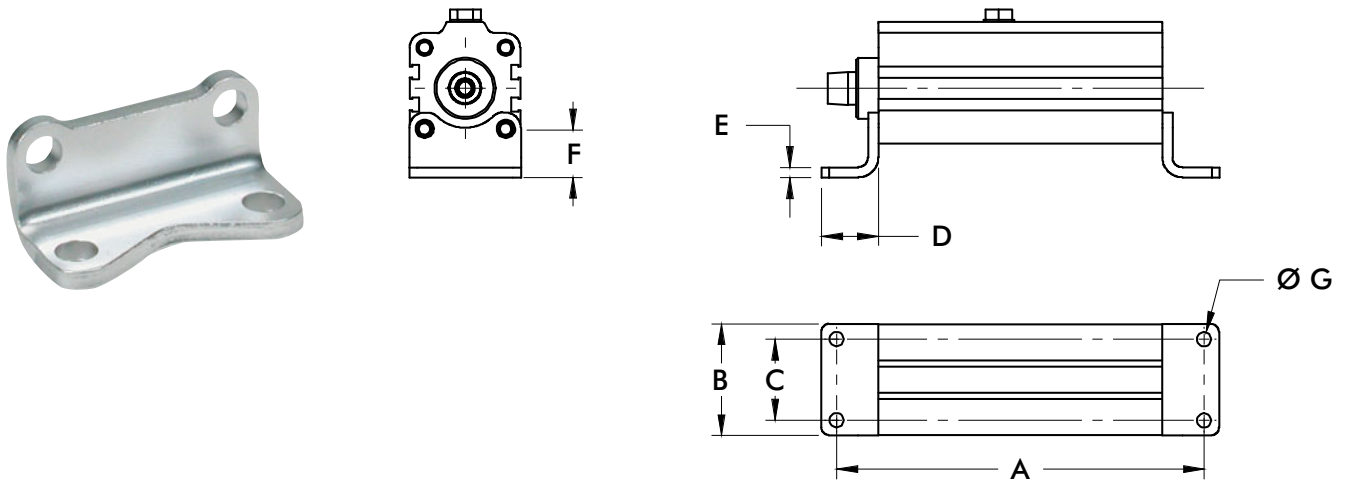

| Part Number | Used with Model/series | A | B | C | D | E | F | G | Weight [lbs], kg |
|------------------|------------------------|------------------|--------------|--------------|--------------|-------------|--------------|--------------|------------------|
| 8MW-018-1 | 89R20-010-2 | [5.41] 137,5 | [1.38] 35 | [0.87] 22 | [0.87] 22 | [0.16] 4 | [0.63] 16 | | [0.08] 0,04 |
| 8MW-020-1 | 89R32-010-2 | [6.54] 166 | [1.97] 50 | [1.38] 35 | | | [0.71] 18 | [0.28] 7 | [0.15] 0,07 |
| 8MW-021-1 | 89R40-010-2 | [7.13] 181 | [2.17] 55 | [1.57] 40 | [1.10] 28 | [0.20] 5 | | | [0.22] 0,10 |
| | 89R40-025-2 | [8.31] 211 | | | | | [0.94] 24 | | |
| 8MW-022-1 | 89R50-025-2 | [9.39] 238,5 | [2.64] 67 | [1.97] 50 | [1.26] 32 | [0.24] 6 | | [0.35] 9 | [0.33] 0,15 |
| 8MW-023-1 | 89R63-025-2 | [10.37] 263,5 | [3.35] 85 | [2.44] 62 | [1.57] 40 | | [1.06] 27 | [0.43] 11 | [0.52] 0,24 |

Body Mount Flanges

Features:

- For recessed mounting
- Variable height adjustment
- Can be used with switches
- For use with the **89R** Series Pneumatic Swing Clamps

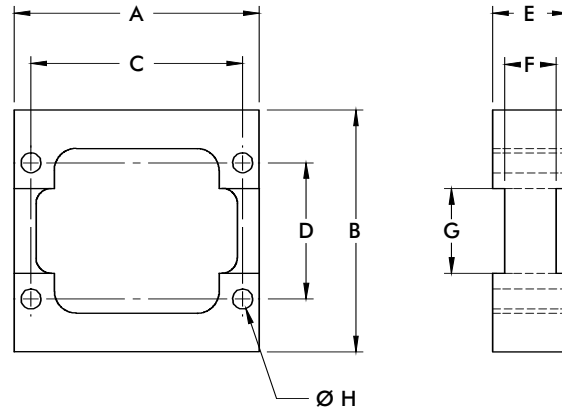

| Part Number | Used with Model/series | A | B | C | D | E | F | G | H | Weight [lbs] kg |
|------------------|------------------------|-----------------|---------------|----------------|--------------|--------------|--------------|--------------|---------------|-----------------|
| 8MA-092-1 | 89R20-010-2 | [2.24] 57 | [2.17] 55 | [1.85] 47 | [0.94] 24 | [0.59] 15 | -- | -- | [0.28] 5,5 | [0.22] 0,10 |
| 8MA-094-1 | 89R32-010-2 | [3.19] 81 | [2.95] 75 | [2.55] 70 | [1.57] 40 | [0.79] 20 | [0.47] 12 | [0.98] 25 | [0.26] 6,6 | [0.44] 0,20 |
| 8MA-095-1 | 89R40-010-2 | | [3.15] 80 | | [1.77] 45 | [0.98] 25 | [0.67] 17 | [1.10] 28 | | [0.55] 0,25 |
| 8MA-096-1 | 89R40-025-2 | [4.00] 101,5 | [3.94] 100 | [3.37] 85,5 | [1.97] 50 | | | [1.46] 37 | [0.35] 9 | [0.88] 0,40 |

End Mount Flanges

Features:

- Can be mounted on bottom side or top side
- For use with **89R** Pneumatic Swing Clamps

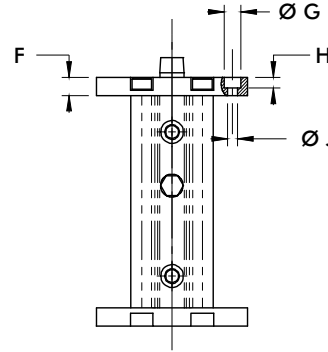
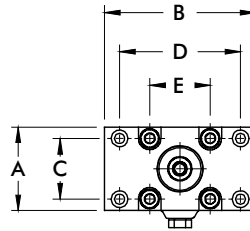
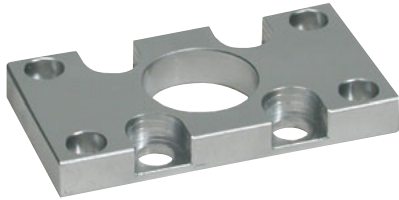

| Part Number | Used with Model/series | A | B | C [±0.008] ±0,2 | D [±0.008] ±0,2 | E | F | G | H | J | Weight [lbs] kg |
|-------------|------------------------|--------------|---------------|-----------------------|-----------------------|--------------|--------------|--------------|-------------|---------------|--------------------|
| 8MA-061-1 | 89R20-010-2 | [1.26] 32 | [2.56] 65 | [0.71] 18 | [1.97] 50 | [0.87] 22 | [0.39] 10 | | | | [0.07] 0,03 |
| 8MA-063-1 | 89R32-010-2 | [1.97] 50 | [3.15] 80 | [1.26] 32 | [2.52] 64 | [1.26] 32 | [0.47] 12 | [0.43] 11 | [0.28] 7 | [0.26] 6,6 | [0.20] 0,09 |
| 8MA-064-1 | 89R40-010-2 | [2.17] 55 | [3.94] 100 | [1.57] 40 | [3.15] 80 | [1.57] 40 | | | | | [0.29] 0,13 |
| | 89R40-025-2 | | | | | | | | | | |
| 8MA-065-1 | 89R50-025-2 | [2.56] 65 | [4.72] 120 | [1.77] 45 | [3.94] 100 | [1.97] 50 | [0.59] 15 | [0.59] 15 | [0.35] 9 | [0.33] 8,5 | [0.46] 0,21 |
| 8MA-066-1 | 89R63-025-2 | [3.15] 80 | [5.12] 130 | [2.36] 60 | [4.33] 110 | [2.44] 62 | | | | [0.35] 8,8 | [0.66] 0,30 |

Mounting Flanges

Features:

- For use with Threaded Body Pneumatic Swing Clamps
- Variable height adjustment
- For recessed mounting

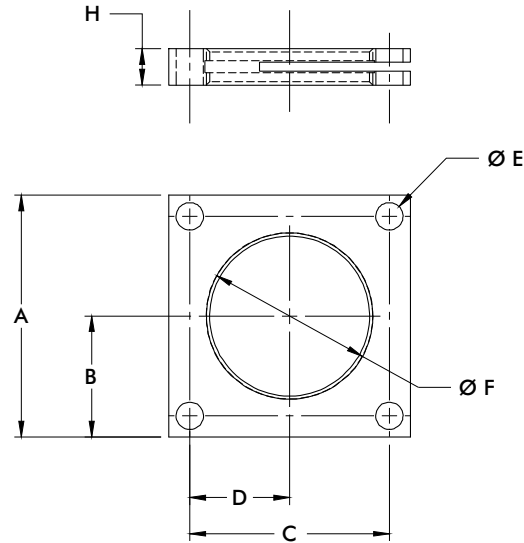
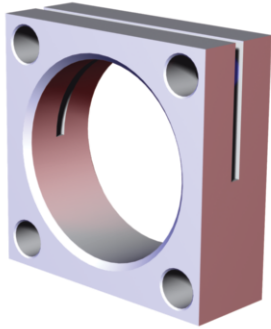

| Part Number | Used with Model/series | A | B | C | D | E | F | H |
|------------------|------------------------|----------------|----------------|----------------|----------------|---------------|----------|----------------|
| 8MA-219-1 | 89E20-010-1 | [2.17] 55 | [4.33] 27,5 | [1.65] 42 | [0.83] 21 | [0.26] 6,6 | M36X1,5 | [0.31] 8 |
| 8MA-220-1 | 89E30-010-1 | [2.76] 70 | [1.38] 35 | [2.13] 54 | [1.06] 27 | | M42X1,5 | [0.39] 10 |
| 8MA-221-1 | 89E40-010-1 | [3.15] 80 | [1.57] 40 | [2.60] 66 | [1.30] 33 | [0.35] 9 | M55X2 | [0.47] 12 |
| 8MA-222-1 | 89E50-025-1 | [3.54] 90 | [1.77] 45 | [2.99] 76 | [1.50] 38 | | M68X2 | [0.59] 15 |
| 8MA-223-1 | 89E63-008-1 | [4.33] 110 | [2.17] 55 | [3.54] 90 | [1.77] 45 | [0.43] 11 | M80X2 | |
| 801553 | 8015/8016 | [1.38] 35 | [0.69] 17,5 | [1.08] 27,4 | [0.54] 13,7 | [0.20] 5,1 | 1 1/8-16 | |
| 821553 | 8215/8216 | [2.50] 63,5 | [1.25] 31,8 | [2.12] 53,8 | [1.06] 26,9 | [0.28] 7,1 | 2 1/4-12 | [0.50] 12.7 |
| 841550 | 8415/8416 | [2.00] 50,8 | [1.00] 25,4 | [1.60] 40,6 | [0.80] 20,3 | | 1 3/4-12 | |